

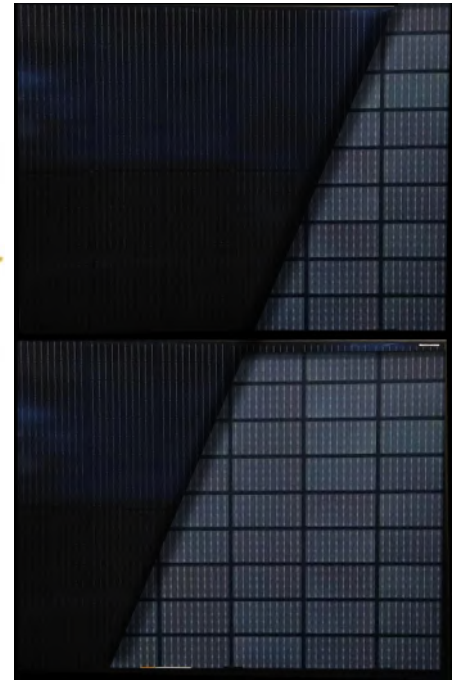

BI-PLUS

DH-M154T 390-410W

Bifacial Half-cut Mono PERC Module



Advanced processing techniques realize great module efficiency to a maximum of 21.0%, steady power output guaranteed



0~+5W Positive tolerance delivers higher output reliability



Excellent performance even under low-light settings, such as dawn, dusk and cloudy day

PID

Advanced cell technology and qualified materials lead to high resistance to PID



Excellent mechanical load resistance: wind loads (2400Pa) & snow loads (5400Pa)



Reliable quality leads to a better sustainability even in harsh environment like desert, farm and coastline

LINEAR PERFORMANCE WARRANTY

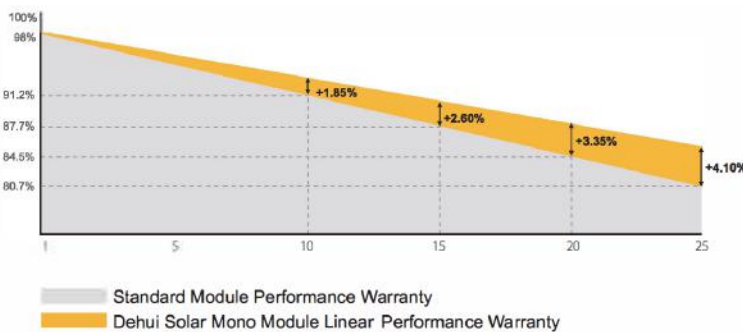

Product Material & Workmanship
12 YEAR WARRANTY

Linear Performance
25 YEAR WARRANTY



DH-M154T 390-410W

Bifacial Half-cut Mono PERC Module

ELECTRICAL PROPERTIES STC*	DH-M154T 390W	DH-M154T 395W	DH-M154T 400W	DH-M154T 405W	DH-M154T 410W
Peak Power (Pmax W)	390	395	400	405	410
MPP Voltage (Vmp V)	30.6	30.9	31.0	31.2	31.5
MPP Current (Imp A)	12.73	12.81	12.90	12.98	13.04
Open Circuit Voltage (Voc V)	36.9	37.0	37.1	37.2	37.3
Short Circuit Current (Isc A)	13.61	13.70	13.79	13.87	13.95
Module Efficiency (%)	20.0	20.2	20.5	20.7	21.0
Power Tolerance	0~+5W				
Operating Temperature	-40°C ~ 85°C				
Maximum System Voltage	DC 1500V				
Maximum Series Fuse Rating	30A				

*STC (Standard Test Condition): Irradiance 1000W/m², Cell Temperature 25°C, AM 1.5

ELECTRICAL PROPERTIES NOCT*	DH-M154T 390W	DH-M154T 395W	DH-M154T 400W	DH-M154T 405W	DH-M154T 410W
Peak Power (Pmax W)	290	294	298	301	305
MPP Voltage (Vmp V)	28.2	28.4	28.6	28.7	29.0
MPP Current (Imp A)	10.28	10.34	10.42	10.48	10.53
Open Circuit Voltage (Voc V)	34.8	35.0	35.0	35.1	35.2
Short Circuit Current (Isc A)	10.99	11.07	11.14	11.20	11.27

*NOCT (Nominal Operating Cell Temperature): Irradiance 800W/m², Ambient Temperature 20°C, AM 1.5, Wind Speed 1m/s

BIFACIAL OUTPUT-REAR SIDE POWER GAIN					
5% Maximum Power(Pmax W)	410	415	420	425	431
5% Module EfficiencySTC (%)	18.98%	19.22%	19.46%	19.71%	19.95%
15% Maximum Power(Pmax W)	449	454	460	466	472
15% Module EfficiencySTC (%)	20.78%	21.05%	21.32%	21.58%	21.85%
25% Maximum Power(Pmax W)	488	494	500	506	513
25% Module EfficiencySTC (%)	22.59%	22.88%	23.17%	23.46%	23.75%

Data may vary according to different environment

MECHANICAL PROPERTIES	
Cell Type	Mono cell(182x91mm)
Number of Cells	108(54*2)
Dimension	1722*1134*30mm
Weight	22kg
Front/Rear Glass	3.2mm
Frame	Anodized aluminum alloy frame
Junction Box	IP68, 3 Diodes
Cable Type	4.0 mm ²
UL Fire Type	UL Type 1 / IEC Class C
Length of Cable	300mm, length can be customized

TEMPERATURE COEFFICIENT	
Temp. Coeff. Of Pmax (TK Pmax)	-0.35%/°C
Temp. Coeff. Of Voc (TK Voc)	-0.28%/°C
Temp. Coeff. Of Isc (TK Isc)	0.048%/°C

PACKAGING	
Pallet	36 pcs
40'HC	936 pcs

The specifications and key features contained in this datasheet maybe changed, modified or updated at any time under sole discretion of Dehui, without further notice to the user, due to the on-going research and development efforts and continuous product improvement processes employed at the factory. Therefore, Dehui reserves the right to make any adjustment to the information contained herein. It is the responsibility of the user of datasheet to obtain the latest, current revision - matching to the correct Dehui product - that the user has purchased or intends to purchase.

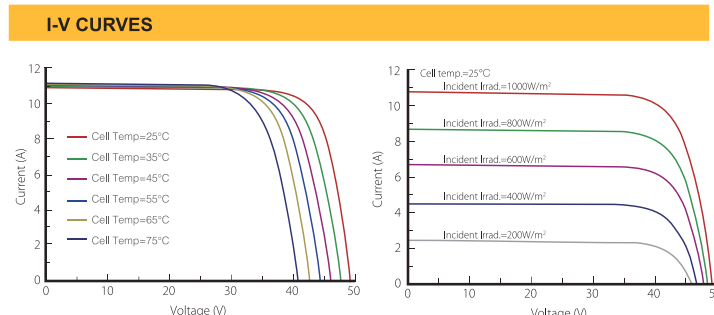
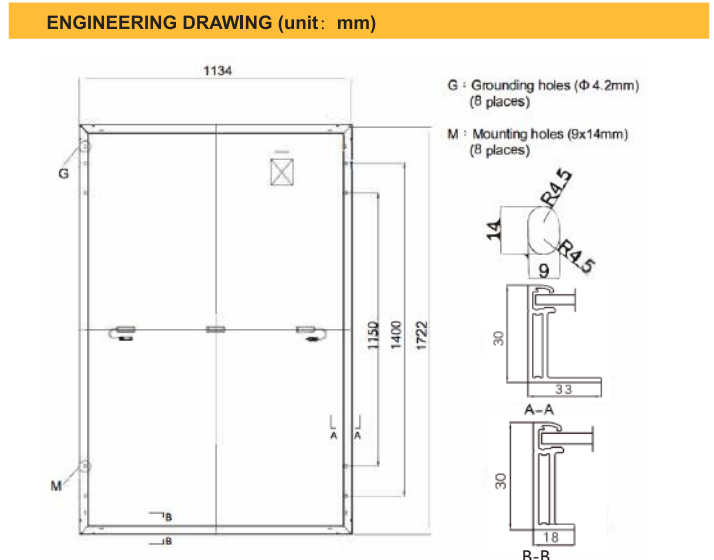

Email: sales@dehui-technology.com
Website: www.dehui-technology.com

U.S.A Office: 14820 Central Avenue, Chino, CA 91710
China Office: Floor 28, Hang Lung Plaza, Wuxi, China
Germany Office: Sebastian-Kneipp-Str.41 60439 Frankfurt, Germany
Factory Add: Lot H2-1-5 & Lot H2-1-6 Dai Dong-Hoan Son Industrial Park, Bac Ninh Province, Vietnam

